



12 litre Round

RC Series

Product Specifications

Container

Product Code:	RC1200
Description:	12 Litre Round
Brimful Volume:	14.50 Litres
ISO Volume:	13.80 Litres
Tamper Evident:	No

Material



Tub:	Polypropylene
Lid:	Polypropylene
Handle:	Metal

Weight

Tub:	415 grams
Lid:	91 grams
Handle:	39 grams

Performance

Storage Temperature:	0°C - 40°C*
Shelf Life:	Minimum 12 months
Static Load on bottom Pail:	Maximum 85 kg at 20°C
Suitable for Hot Filling:	Yes* (Above 70°C See note)

Compatibility

Some chemicals, and process parameters, can affect the integrity of the container. The buyer must undertake testing and approval for the container's suitability for the product and application.

Regulatory

Raw materials used are REACH compliant, approved for food contact and meet FDA regulations.

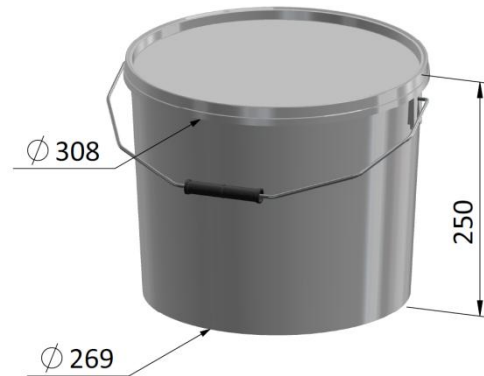

Decoration

Tub IML:	Yes
Lid IML:	No
Colours:	White, others on request

Palletisation

Lid Pallet Quantity:	902
Bucket Pallet Quantity(Empty):	220
Units per layer:	11
Bucket Pallet Quantity (Filled):	55

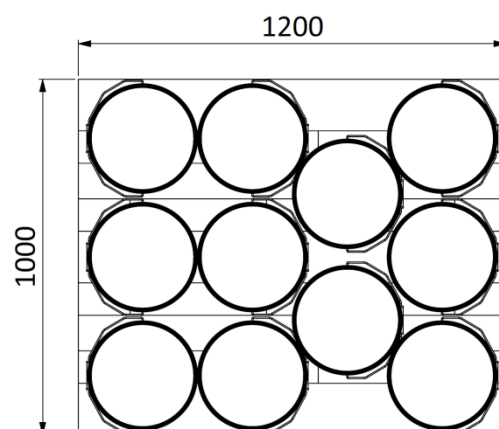

Standard tolerance of ±5%

*Special blends and additives available for non standard conditions.

Specifications can be modified without notice; please contact your OnePlastics representative to ensure you have the most recent information.