



4 Litre Square Container

FS Series

Product Specifications

Container

Product Code:	FS4000
Description:	4 Litre Square Container
Brimful Volume:	4.32 Litres
ISO Volume:	4.07 Litres
Tamper Evident:	No

Material

Tub:	Polypropylene
Lid:	Polypropylene



Weight

Tub:	92 grams
Lid:	29 grams

Performance

Storage Temperature:	0°C - 40°C*
Shelf Life:	Minimum 12 months
Static Load on bottom Pail:	Maximum 48 kg at 20°C
Suitable for Hot Filling:	Yes* (Above 70°C See note)
Suitable for Tinting:	No

Compatibility

Some chemicals, and process parameters, can affect the integrity of the container. The buyer must undertake testing and approval for the container's suitability for the product and application.

Regulatory

Raw materials used are REACH compliant, approved for food contact and meet FDA regulations.



Decoration

Tub IML:	Yes (3 sides)
Lid IML:	Yes
Colours:	White, others on request

Palletisation

Lid Pallet Quantity:	4500
Bucket Pallet Quantity (Empty):	1080
Units per layer on a pallet:	30
Layers per pallet:	36
Bucket Pallet Quantity (Filled):	240
Tub Box Quantity (Empty)	90

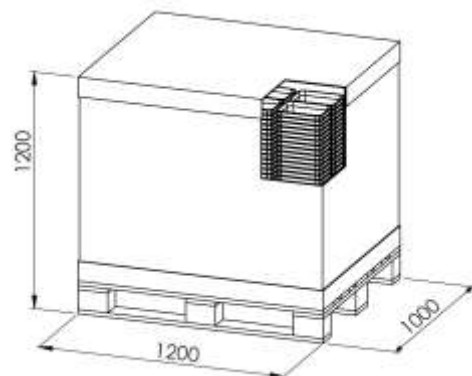

Standard tolerance of ±5%

*Special blends and additives available for non standard conditions.

Specifications can be modified without notice; please contact your OnePlastics representative to ensure you have the most recent information.